

Προδιαγραφή οικιακών ρυθμιστών

LOW PRESSURE REGULATOR FOR RESIDENTIAL & COMMERCIAL APPLICATIONS

ΣΥΝΤΑΞΗ:

**ΜΗΧΑΝΙΚΟΣ
ΠΡΟΔΙΑΓΡΑΦΩΝ ΚΑΙ
ΣΥΜΒΑΣΕΩΝ**

ΕΛΕΓΧΟΣ:

**ΕΠΙΤΡΟΠΗ ΠΡΟΔΙΑΓΡΑΦΩΝ
ΕΔΑ ΑΤΤΙΚΗΣ**

ΕΓΚΡΙΣΗ:

**ΕΠΙΧΕΙΡΗΣΙΑΚΟΣ
ΔΙΕΥΘΥΝΤΗΣ ΔΙΑΝΟΜΗΣ**

Προδιαγραφή οικιακών ρυθμιστών

Contents

1. General	3
1.1 Scope.....	3
1.2 Operating Characteristics.....	3
2. General Construction Requirements for both Underground and (or) Wall Mounded Regulators	3
3. Special requirements for underground regulators	4
4. Special requirements for Wall-mounted regulators	5
5. Tests	5
6. Certification	6
7. Marking	6
8. Delivery	6
9. Annexes	7
ANNEX 1	7
Annex 2	8
Annex 3	8

Προδιαγραφή οικιακών ρυθμιστών

1. General

1.1 Scope

This specification is referred to service regulators designed for use on domestic or commercial applications.

1.2 Operating Characteristics

Nominal flow: 6,10,16,25,40,50,75,100 Nm³/h

Inlet pressure 1- 4 bar

Outlet pressure 25 mbar (unless otherwise determined at the order)

2. General Construction Requirements for both Underground and (or) Wall Mounded Regulators

The equipment to be implemented must have unquestionable references of similar use elsewhere and must be properly designed for the required operating conditions (operating pressure and temperature, nature of fluid).

Regulators shall be constructed according to the applicable international or national standards of the members of European Union. The materials shall be proper to adapt in sudden change of environmental temperature. Leaks in case of sudden change of environmental temperature shall be considered as a clue of poor material / end product quality.

7

The inlet connection of the regulator must be sphero-conical. Regulators shall be capable to operate under ambient temperatures determined in “Directive 2014/32/EU”. Regulators should allow for adjusting the outlet setting pressure, the outlet overpressure and the outlet under pressure on site.

Regulators must be equipped with outlet pressure test point.

Other requirements:

Two stage diaphragm type regulator

Incorporated shut-off valve activated in case of:

- Outlet under pressure
- Outlet over pressure
- ✓ Integrated relief valve activated in case of:
 - outlet pressure above specification (overpressure)
- ✓ Manually operated, specially designed reset lever
- ✓ Excess Flow

Προδιαγραφή οικιακών ρυθμιστών

- ✓ Safety shut-off device for the lack of feeding
- ✓ Safety shut-off for second stage diaphragm failure, diaphragm bursting
- ✓ Protective filter fitted to the regulator inlet
- ✓ Maximum noise level of the regulator : 70dB
- ✓ The following features shall be recorded:
 - AC (less or equal to 10)
 - SG (less or equal to 20)

Where SG is the maximum permissible positive difference between the actual lock-up pressure P_f and the set point P_{as} , expressed as a percentage of the set point P_{as} , e.g.

$$SG = (P_f - P_{as})/P_{as} * 100$$

The isolation valve fitted upstream the regulator shall be according to ELOT EN 331. It shall incorporate a mechanical compression joint for the connection with the PE pipe. A pressure tap shall be installed before the regulator.

3. Special requirements for underground regulators

Regarding the underground regulators the following requirements must be satisfied:

- 7 1. Along with the regulator a flexible vent PE or metallic pipe (PN 6), must be delivered. The flexible pipe must be delivered in coils approximately 8 m long. It shall have a grid and a protective cap at one end. The venting pipe shall be fitted to the box of the regulator at the field by the contractor and the length of the venting pipe must be adjustable at the field depending on the requirements of the specific service line. Proper fittings to fix the venting pipe must also be delivered.
2. The configuration of the inlet and outlet pipe will be aligned. The inlet and the outlet pipe shall be installed as close to the bottom of the protective box and at least 50 -60cm from the cover of the protective box . The inlet and outlet pipe will end at a compressive coupler (joint), which will enable a PE pipe to be fitted. All parts of the underground module (relief valves, regulators, compressive joints etc) shall be protected against corrosion with proper dyeing.)The manufacturer must declare conformity of the anticorrosive protection to the applicable international or national standards of European Union members.
3. The relief valve shall not release gas inside the protective box but in the open air. The manufacturer shall provide a solution, which will be examined and accepted by the evaluation committee. It shall be noted that the whole regulation set must have only one venting pipe terminating at the external environment. All possible leaks from the underground module must be directed through the venting pipe of the box to the external environment.
4. The underground regulator shall be constructed in such a way to ensure proper (normal) function even when the regulator is fully merged into water and mud.

Προδιαγραφή οικιακών ρυθμιστών

5. Proper fitting to fix the inlet and outlet pipe to the inlet and the outlet of the box must be delivered
6. Installation manual for the underground regulator must be delivered

4. Special requirements for Wall-mounted regulators

Regarding wall mounted regulators the following requirements must be respected:

1. The protective box of the wall mounded regulator shall be according to EDA-008 specification and shall have ventilation on the front face of the box. The outlet-coupling pipe shall not be incorporated in the supply by the manufacturer. The drawing in ANNEX 1 portrays just an indicative configuration.
2. The outlet of the regulator shall be determined at the order. Hence, the manufacturer shall make proper provisions at the protective box. If the outlet of the regulator is requested at the top right of the protective box the regulator will be L type otherwise, it will be U type.
3. Proper space for easy handling shall be allowed in the protective box of the wall mounted regulators in order to assist easy assembly of the outlet pipe. The manufacturer is required to submit IFC for approval. Proper transition fitting (nipple) will be applied at the outlet of the regulator. At the tender documents the material of the outlet pipe (PE or galvanized) will be determined
4. In case in the outlet of the regulator a PE pipe is fitted then a compressive joint (will be provided at the end of the transition fitting (nipple). If in the outlet of the regulator a galvanized pipe is fitted then the outlet of the transition fitting shall be threaded (thread joint)

All parts of the wall-mounted module shall be protected against corrosion with proper dyeing. The manufacturer must declare conformity of the anticorrosive protection to the applicable international or national standards of European Union members.

5. Tests

5.1 Tests must be conducted ensuring AC, SG and also:

- The regulator pressure set point
- The slam shut valve pressure set

5.2 Tightness tests

Mechanical fittings under pressure (i.e. gaskets) as well as test points for repair, calibration and alteration purposes must be mechanically jointed to the regulator and tight under normal operating conditions. External tightness of the connections must be tested by the manufacturer.

5.3 Internal tightness of the regulator itself under normal operating conditions shall be verified. Test reports ensuring the internal tightness of the regulator are required.

Προδιαγραφή οικιακών ρυθμιστών

6. Certification

A certificate (3.1, EN 10204) is required for the regulator.

The certificate must be accompanied with a report ensuring that the requirements of paragraph 5.1. above are met. The report must also contain the following data:

- AC and SG.
- The regulator pressure set point and design pressure range
- The slam shut valve pressure set point

7. Marking

An arrow marked on the body of the regulator shall indicate the direction of the gas flow. It is also required a conveniently positioned label, indicating the followings:

- Manufacturer and/ or common name in the trade
- Type of the regulator
- Serial number
- Year of production
- Design pressure range.
- Outlet pressure
- CE mark

8. Delivery

The packaging for delivery shall be designed so as to avoid any deterioration during handling, transporting and storing.

Προδιαγραφή οικιακών ρυθμιστών

9. Annexes

ANNEX 1: Indicative configuration of a low pressure regulator installed in a box

ANNEX 2: Indicative technical solution for the vending pipe

ANNEX 3: Indicative dimensions of inlet PE pipe

ANNEX 1

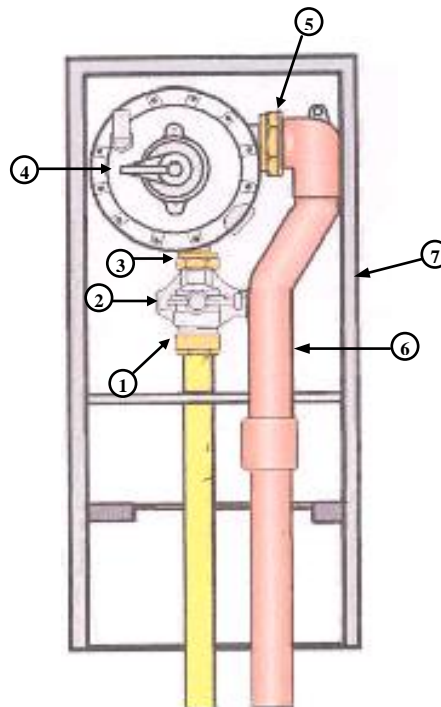

Fig. 2: Indicative configuration of a low-pressure regulator installed in a box. The protective box shall be properly constructed to permit an alternative outlet from the right side view of the box.

Ref. No.	DESCRIPTION
1	Mechanical compression joint incorporated to the valve
2	Isolation valve
3	Spheroconical coupling
4	Low Pressure Regulator
5	Flat joint connection (gasket)
6	Outlet coupling pipe (not to be supplied)
7	Protective box

Προδιαγραφή οικιακών ρυθμιστών

Annex 2

Regarding underground regulators, in order to avoid the ingress of water and the subsequent failure of the regulator, the following solution is proposed:

The venting pipe of the relief valve should be half the diameter of the central venting pipe of the regulating set and shall terminate within the central venting pipe slightly above the surface level.

Annex 3

Indicative dimensions of inlet PE pipe:

For regulators

1. R6-R16 inlet $\Phi 20$
2. R25-R65 inlet $\Phi 32$
3. R100 inlet $\Phi 32$ —The abovementioned dimensions must be followed unless otherwise determined at the order.