



διανομή αερίου
αττικής
ΕΤΑΙΡΕΙΑ ΔΙΑΝΟΜΗΣ ΑΕΡΙΟΥ ΑΤΤΙΚΗΣ Α.Ε.

ΤΕΧΝΙΚΗ ΠΡΟΔΙΑΓΡΑΦΗ

ΕΔΑ -MR- 007/0

ΕΔΑ ΑΤΤΙΚΗΣ

**LOW PRESSURE OUTLET REGULATOR
FOR SMALL DISTRICT APPLICATIONS.
INLET PRESSURE: 0.5 to 5 Bar, OUTLET PRESSURE: 25 mbar**

Σύνταξη:

ΤΜΗΜΑ ΤΕΧΝΙΚΗΣ ΥΠΟΣΤΗΡΙΞΗΣ ΕΔΑ
ΑΤΤΙΚΗΣ

Έγκριση:

ΕΠΙΤΡΟΠΗ ΠΡΟΔΙΑΓΡΑΦΩΝ ΕΔΑ
ΑΤΤΙΚΗΣ

ΕΠΙΤΡΟΠΗ ΤΕΧΝΙΚΗΣ
ΔΙΕΥΘΥΝΣΗΣ ΕΔΑ ΑΤΤΙΚΗΣ

1/8/03

ΣΕΛΙΔΕΣ
7

CONTENTS

1. GENERAL

1.1 SCOPE

1.2 OPERATING CHARACTERISTICS

2. GENERAL CHARACTERISTICS

2.1 CONSTRUCTION REQUIREMENTS

2.2 ASSEMBLIES

3. TESTS

4. MARKING

5. DOCUMENTATION

6. DELIVERY

7. ANNEXES

1.1 SCOPE

This specification refers to **small District, single stream, Underground Regulator Stations**.

1.2 OPERATING CHARACTERISTICS

Nominal flow ; **Type 1 160 nm³/h**

Type 2 500 nm³/h

Inlet operating pressure: 0,5- 5 bar

Outlet operating pressure: 25mbar

Maximum Velocity before Filter 30metres/sec

The Maximum velocity after Regulator must ensure the normal function of the regulator and must not exceed 40 metres/sec.

Design pressure (DP) up to and including the regulator is 16bar.

Design pressure (DP) after the regulator is 10bar.

Design factor (f_o) for the calculation of pipe wall thickness is 0,4.

2. GENERAL CHARACTERISTICS

2.1 CONSTRUCTION REQUIREMENTS

The equipment to be implemented shall be of the best quality, must conform to PED 97/23, must have unquestionable references of similar use elsewhere and must be properly designed for the required operating conditions (operating pressure and temperature, nature of fluid - **Natural Gas**).

The Regulator shall be constructed according to ELOT EN 334 "Gas pressure regulators for inlet pressures up to 100 bar" or other national standard of a European Union member – country.

The connecting threads for the regulator, valves, etc. should conform to ISO 7-1. All Flanges, bolts and gaskets should comply with PN16.

The springs used in the regulator should conform to ISO 2162-2

The regulator shall be capable to operate under ambient temperature between -20°C and 60°C , according to ELOT EN 437.

Other requirements:

Station Capacity: **Type 1. 160 nm³/h**

Type 2. 500 nm³/h

The stream shall comprise

- **Steel Stream inlet (ball / fire safe) full bore valve**
- **Filter**

Filtration level = 5 micron

Maximum permissible DP across filter = 30mb

- Slam shut Valve (manual reset) which closes under High / Low Outlet Pressure
- Creep Relief Valve 1% of design capacity.

- An external vent pipe if fitted to the outlet of the creep relief valve should terminate at least 2 metres above ground level.
- Direct acting active pressure regulator.

Regulators up to 2" dia. may have be either screwed connections or flanged connections to PN16. The outlet flange shall be compatible with the PE flange installed at the downstream PE network.

Nb both the Slam shut and relief valve can be an integral part of the pressure regulator

- Steel Stream outlet, ball, gate or butterfly valve –Bypass valves as specified in Type 1 Stations shall be as per the inlet/outlet valves on the regulator stream.
- All interconnecting steel pipe should of Standard API 5L grade B of wall thickness:
Up to 6" dia. = 4.8mm
8-12" dia. = 6.35mm
- All butt-welding shall be in accordance with API 1104 or equivalent EN standards, and shall include 100 % testing of joints upstream of the regulator and 30% joints downstream.
- Type 1 - 160 ncm / h Station: Pipe work and fittings can be screwed connections.

The inlet / outlet connections shall terminate in Sphero-conic joints(included to the station protective box) suitable for connection to PE80 SDR11.

Type2 - 500 ncm / h Stations: all pipe work and fittings shall have flanged connections to PN16 or PE/steel ends with PE80 SDR11.

In case of flanged connections, the inlet / outlet connections shall terminate in flanges to PN16. The flange of PE pipe that will be connected to the MRS flange is according to ISO 36-63.

- Pressure gauges of appropriate range shall be included for inlet/outlet pressure measurement.
- The filter will be equipped with differential pressure gauge and drain.
- Type 2. 500 nm³/h Stations only: A 7 day pressure recorder shall be included for the measurement of outlet pressure only
- Maximum noise level pit open: 70dB
- Type 1 - 160 nm³ / h Station: The station will be provided with one extra equivalent by pass equipped with a regulator. This by pass has to be installed each time we have to interrupt the operation of the main stream.

The following features shall be recorded:

- Accuracy under normal conditions
- SG, where SG is the maximum permissible positive difference between the actual lock-up pressure P_f and the set point P_{as} , expressed as a percentage of the set point P_{as} , e.g.

$$SG = (P_f - P_{as}) / P_{as} * 100$$

- SZ, where SZ is the maximum permissible lock up pressure zone for specified:
 - a. Inlet pressure P_e or inlet pressure range b_{pe} and
 - b. set point P_{as} or specific set range W_b or set range W_h

It is expressed as the percentage of $Q_{min,Pe}$ to $Q_{max,Pe}$, i.e.

$$SZ = Q_{min,Pe} / Q_{max,Pe}$$

RG should be ≤ 5

SG should be ≤ 10

Stations in pits should be in accordance with EN12186:2000 (Page11). The design of the stream will permit the easy disconnection of the whole stream, replacement with a redundant stream and maintenance or repair to an external laboratory. The roof of the pit and/ or cover should be designed to either withstand the weight of heavy traffic or be protected by barriers. The pit shall be constructed so as to prevent the ingress of water or other extraneous materials. The pits shall be adequately protected against corrosion.

3 TESTS

3.1 Tests must be conducted under ambient temperature ensuring

- The accuracy level
- The maximum response time
- The regulator pressure set point
- The slam shut valve pressure set point
- The accuracy for the design flow range of the regulator
- **The whole assembly should be subjected to a strength test 1,5 time the design pressure (DP) for 2 hours not including the regulator, relief valve and similar equipment.**

3.2 Tightness tests

All fittings and connections under pressure, shall conform to ELOT EN 334

Mechanical fittings under pressure (i.e. gaskets) as well as test points for repair, calibration and alteration purposes must be mechanically jointed to the regulator and tight under the normal operating conditions.

3.3 Internal tightness of the regulator itself shall be according to ELOT EN 334. Test Certificates ensuring the internal tightness of the regulator and the pressure set points are required. The aforementioned tests must be conducted under:

- The minimum flow $Q_{\min, pe}$ and
- The boundary conditions for the inlet pressure and set point P_{as} or
- the boundary conditions of the set - point range.

3.4 On site tightness tests

The whole assembly should be subject to a tightness test after the installation on site for a half hour at the operating pressures.

4 MARKING

An arrow marked on the body of the regulator shall indicate the direction of the gas flow. It is also required a conveniently positioned label, indicating the followings:

- Manufacturer and/ or common name in the trade
- Type of the regulator
- Serial number
- Year of production
- Nominal sizes of inlet and outlet fittings

- Design pressure range.
- Outlet pressure
- Pressure set point for the slum shut valve
- CE mark

5 DOCUMENTATION

A book including the following must be delivered with each station:

- list of material and equipment with reference at the station's drawing
- welding log list
- as built drawings (IFC drawings should be approved before construction)
- installation instructions
- operation & maintenance manuals
- test certificates for equipment and materials
- radiographic films should be available at any time at the manufacturer's representative in Greece
- list of recommended spare parts with the manufacturer's serial numbers

6 DELIVERY

The packaging for delivery shall be designed so as to avoid any deterioration during handling, transporting and storing.

7 ANNEXES

ANNEX I: Schematic layouts of a 160 / 500 nm³/h, single stream District Stations.

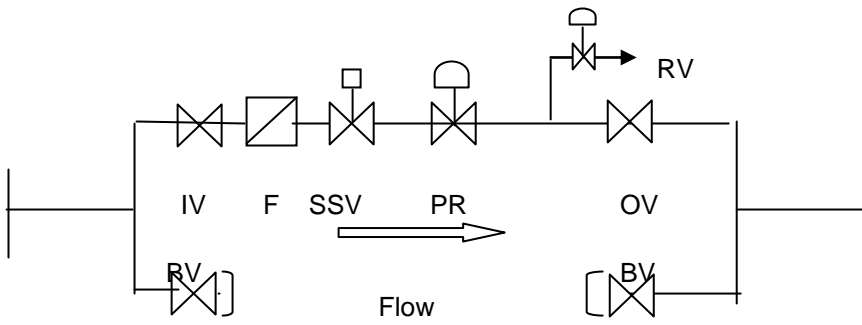

leave provision for temp. bypass

Nb.both the Slam shut and the creep relief valve can be an integral part of the Pressure Regulator